

FITTING INSTRUCTION

Clamp mark in acc. with		Cables joining
ISO	PN	
1	L	Left directional lights
2	+	Rear fog lights
3	31	Ground
4	R	Right directional lights
5	58R	Right side parking lights
6	54	Stoplights
7	58L	Left side parking lights

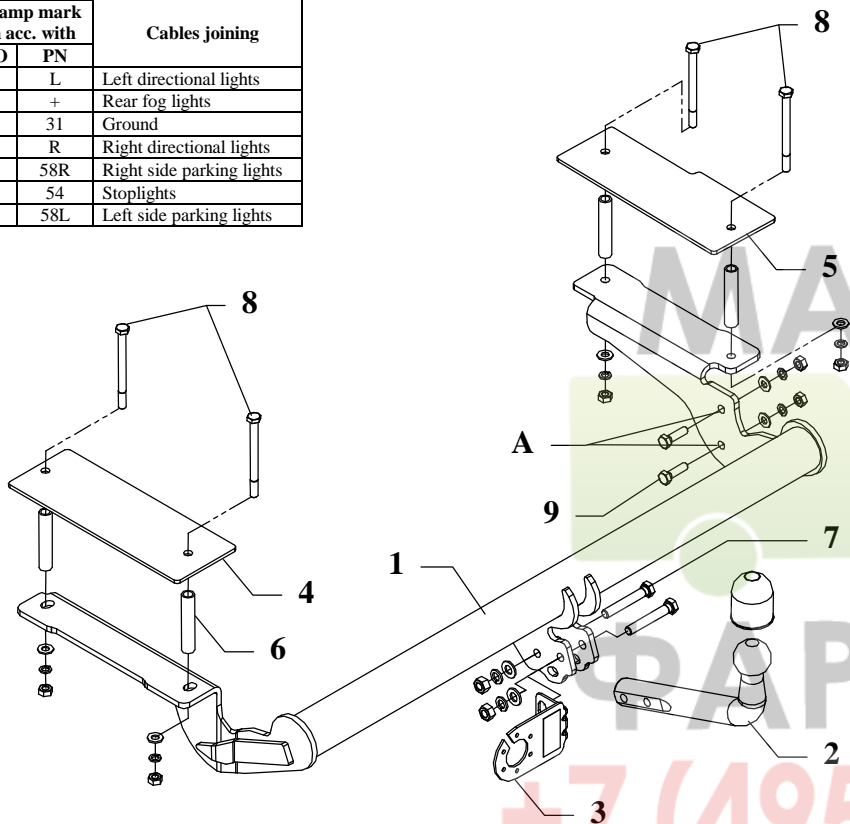

This towbar is designed to assembly in following cars:
OPEL ASTRA "B" ESTATE, produced since 03.1998 till 2004, catalogue no. **E23** and is prepared to tow trailers max total weight **1500 kg** and max vertical load **75 kg**.

From manufacturer

Thank you for buying our product. Their reliability has been confirmed in many tests. Reliability of towbar depends also on correct assembly and right operation. For this reasons we kindly ask to read carefully this instruction and apply to hints.

The towbar should be install in points described by a car producer.

The instruction of the assembly

1. Disassemble the bumper and the rear and side panel`s covers (inside the boots), then draw the fitted carpet back.
2. Disassemble the silencer and the thermal panel.
3. Find three holes marked on the left and right side, then drill two holes (the first and last one) using $\varnothing 17\text{mm}$.
4. Put the sleeves (pos. 6) and the fish-plates (pos. 4 and 5) through these holes, and then put the bolts M10 x120mm (pos. 8).
5. Position the main bar of the towbar (pos. 1) at the bottom of car, and then fit it.
6. Fit the towing eye through the towing eye`s fabric holes and the holes (pos. A). Use bolts M10x35mm (pos. 9).
7. Disassemble the foam from the bumper, then cut the bumper little and reassemble the bumper.
8. Fix the ball of towbar (pos. 2) with socket plate (pos. 3) using M12x75mm (pos. 7) screws from the towbar accessories.
9. Reassemble the silencer and the thermal cover.
10. Tighten all nuts and bolts according to the torque shown in the table.
11. Connect the electric wires according to the instructions of the car.
12. Complete the paint cover of towbar (during the mounting paint cover could be destroyed).

Torque settings for nuts and bolts (8,8):	
M 8 - 25 Nm	M 10 - 55 Nm
M 12 - 85 Nm	M 14 - 135 Nm











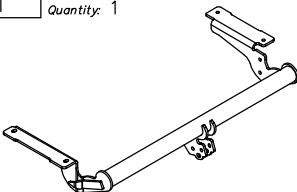
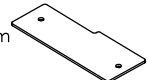

NOTE

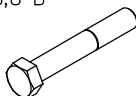
After install the towbar you should get adequate note in registration book (at authorised service station).The car should be equipped with:

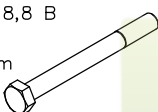
- Indicators
- Tow mirrors

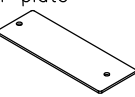
After 1000km check all bolts and nuts. The ball of towbar must be always kept clear and conserve with a grease.

Towbar accessories:

Pos. 1 Name: Main bar Quantity: 1 	Pos. 5 Name: Right fish-plate Quantity: 1 Dim.: 295x112x5mm 	Pos. 11 Name: Nut 8 B Quantity: 6 Dim.: M10 
	Pos. 6 Name: Distance sleeve Quantity: 4 Dim.: Ø17,2x2,35; L=88mm 	Pos. 12 Name: Plain washer Quantity: 2 Dim.: Ø 13 mm 
Pos. 2 Name: Tow ball Quantity: 1 	Pos. 7 Name: Bolt 8,8 B Quantity: 2 Dim.: M12x75mm 	Pos. 13 Name: Plain washer Quantity: 6 Dim.: Ø 10,5 mm 
Pos. 3 Name: Socket plate Quantity: 1 	Pos. 8 Name: Bolt 8,8 B Quantity: 4 Dim.: M10x120mm 	Pos. 14 Name: Spring washer Quantity: 2 Dim.: Ø 12,2 mm 
Pos. 4 Name: Left fish-plate Quantity: 1 Dim.: 310x110x5mm 	Pos. 9 Name: Bolt 8,8 B Quantity: 2 Dim.: M10x35mm 	Pos. 15 Name: Spring washer Quantity: 6 Dim.: Ø 10,2 mm 
	Pos. 10 Name: Nut 8 B Quantity: 2 Dim.: M12 	Pos. 16 Name: Ball cover Quantity: 1 



PPUH AUTO-HAK S. J.

Produkcja Haków Holowniczych
Henryk & Zbigniew Nejman
76-200 SŁUPSK ul. Słoneczna 16K
tel/fax (059) 8-414-414; 8-414-413
E-mail: office@autohak.com.pl
www.autohak.com.pl

Towing hitch (without electrical set)

Class: **A50-X** Cat. no. **E23**

Designed for:

Manufacturer: **OPEL**

Model: **ASTRA "B"**

Type: **ESTATE**

produced since 03.1998 till 2004

Technical data:

D-value: 7,9 kN

maximum trailer weight: **1500 kg**

maximum vertical cup load: **75 kg**

Approval number acc. to regulations EKG/ONZ 55.01: E20-55R-01 0734

Foreword

This towbar is designed according to rules of safety traffic regulations. The towing hitch is a safety component and can be install only by qualified personnel. Any alteration or conversion of the towing hitch is prohibited and would lead to cancellation of design certification. Remove insulating compound and underseal from vehicle (if present) in the area of the matting surfaces of the towing hitch. The vehicle manufacturer's specifications regarding trailer load and max. vertical cup load are decisive for driving, and values for the towing hitch cannot be exceeded.

D-value formula:

$$\frac{\text{Max trailer weight [kg]} \times \text{Max vehicle weight [kg]}}{\text{Max trailer weight [kg]} + \text{Max vehicle weight [kg]}} \times \frac{9,81}{1000} = D \text{ [kN]}$$